



#50-682SM
#50-682SF

**Metal Flex - Connector
Installation Instructions:**

WARNING		
	<p>Electrical Shock Hazard. Contact with high voltage may cause falling, serious injury, or death. Disconnect power before servicing.</p>	
	<p>Electrical Fire Hazard. Use in application exceeding voltage and current ratings listed can cause an electrical fire resulting in serious injury or death. Only use in accordance with Table 1 and local electrical wiring code.</p>	

Installation Instructions:

1. Match PowerPlug® Disconnect-Model 182S half with same gender metal flex-connector half. (See FIGURE 1) Pairing 30-682SM with 50-682SM and 30-682SF with 50-682SF.
2. Install anti-short bushing into flex cable.
3. Feed wiring through male metal flex-connector as shown in FIGURE 2.
4. Install wire into PowerPlug® Disconnect as shown in FIGURE 3. See Disconnect (Model 182S) instructions for details.
5. Push PowerPlug® Disconnect into metal flex-connector until snapped into place. Make sure PowerPlug® Disconnect is orientated correctly. See FIGURE 1.
6. Insert flex cable into back end of metal flex-connector. Secure with screw to 8 in.-lbs. See FIGURE 4A and 4B.
7. Repeat steps 1-5 for female assembly (50-682SF and 30-682SF)
8. See de-mate/mate installation instructions on this page when disconnecting the connector.

Figure 1: Male & Female Sub Assemblies

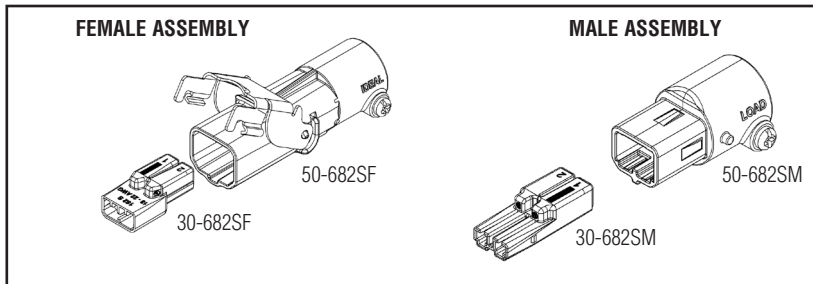

Figure 2: Wires inserted through Metal Flex-Connector

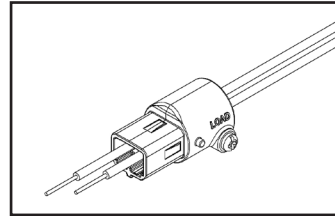

Figure 3: Wires inserted into PowerPlug® Luminaire Disconnect

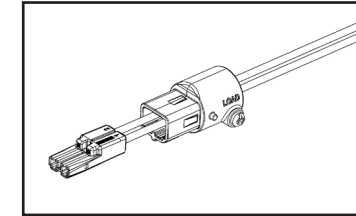
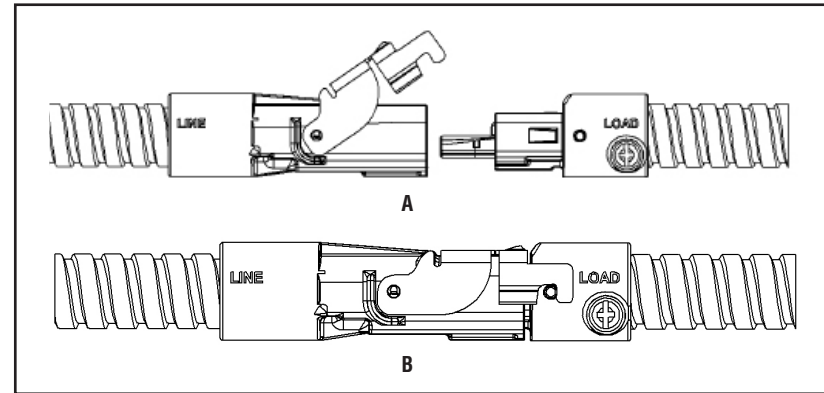

Figure 4: Assemblies (A) Disconnected, (B) Connected



Electrical Specifications

Wiring Class	Rating
Class 2	NEC/CEC Class 2 Circuit only
Not suitable for use in wet locations.	
For additional specifications, reference 30-682SM and 30-682SF instruction sheet, Tables 2 and 3.	

Disconnect de-mate / mate installation

1. To de-mate, rotate latch, pull metal flex-connector halves apart to separate. Do NOT pull on flex cable.
2. To mate, grasp each half, align, and push together. Close latch to ensure full contact and secure mating.
3. Completed connection should appear as shown in FIGURE 4B.

U.S. Patent No. 8,323,048

IDEAL INDUSTRIES, INC.

Becker Place
Sycamore, IL 60178, U.S.A.
800-435-0705 Customer Assistance
www.idealindustries.com

ND 7608-2